

TF03 LiDAR
4-20mA
User Manual



Product

Product Number: TF03 version 4-20mA

Product name: TF03 LiDAR

Manufacturer

Company: Benewake (Beijing) Co., Ltd.

Address: NO.28 Xinxu Road, Haidian District, Beijing, PRC

Copyright

The Copyright of this document is protected. All the rights involved herein belong to Benewake (Beijing) Co., Ltd. Any copy activity of this document, no matter in whole or in part, should be in conformity of the Copyright Law. The actives of modification, omission or translation of this document are not allowed unless a written permission from Benewake (Beijing) Co., Ltd.

All rights reserved © Benewake (Beijing) Co., Ltd.



Forward

Dear users:

Thanks for choosing Benewake products, and it is our pleasure to help you to solve any technical question.

For offering a better operation experience to you, we hereby write this manual for an easier and simpler operation of our product, hoping to solve the common problems in better way you may meet. Please contact us if you have any questions. (bw@benewake.com)

This operation manual covers the product operation introduction and common problem solutions, but it is hard to cover all the problems you maybe meet. So if you have any further questions or problems, please feel free to consult our technical support service (support@benewake.com). We will do our best to solve any problem related to the product. If you have any other good advice or suggestions, welcome to visit our official website and offer us your feedback there (<http://www.benewake.com/feedback.html>), and we are looking forwards to your participation.

We are Benewake who dedicated to making the best “Robotic Eyes” worldwide!



Table of Contents

1	<u>ATTENTIONS</u>	5
1.1	ABOUT THIS DOCUMENT	5
1.2	USAGE OF THE PRODUCT	5
1.3	CONDITIONS WITH POTENTIAL PRODUCT FAILURE	5
2	<u>PHYSICAL INTERFACE</u>	6
2.1	DESCRIPTION ABOUT THE LINE SEQUENCE AND CONNECTION	6
2.2	ELECTRICAL CHARACTERISTICS	7
3	<u>INSTALLATION INSTRUCTIONS</u>	7
3.1	PRODUCT OVERVIEW	7
3.2	PRODUCTS STRUCTURE	7
3.3	DETECTION ANGLE DESCRIPTIONS	8
4	<u>COMMUNICATION PROTOCOL AND DATA FORMAT</u>	9
4.1	COMMUNICATION PROTOCOL	9
4.2	CUSTOM PARAMETER CONFIGURATION	10
4.2.1	INSTRUCTION GENERAL FORMAT DESCRIPTION	10
4.2.2	COMMANDS	11
5	<u>QUICK TEST PROCEDURES</u>	12
5.1	TEST EXAMPLE	12
5.1.1	TEST RANGE WITH DIFFERENT REFLECTIVITY	12
5.1.2	TESTING ACCURACY OF DIFFERENT MATERIALS	12
5.1.3	REFLECTIVITY OF COMMON MATERIALS	13
6	<u>FREQUENTLY ASKED QUESTIONS</u>	14



1 Attentions

1.1 About this Document

- This Manual provides information necessary for the use of this product.
- Please read this Manual carefully before using this product and make sure that you have fully understood its contents.

1.2 Usage of the Product

- Qualified professionals can only maintain this product and only the original spare parts can be used to ensure its performance and safety.
- The product itself has no polarity and overvoltage protection. Please complete wiring and supply power correctly according to the contents of the Manual.
- The working temperature of the product is $-25^{\circ}\text{C}\sim 60^{\circ}\text{C}$; please do not use it beyond this temperature range, to avoid risks.
- The storage temperature of the product is $-40^{\circ}\text{C}\sim 85^{\circ}\text{C}$; please do not store it beyond this temperature range, to avoid risks.
- Do not open its enclosure for assembly or maintenance beyond this Manual; otherwise, it will affect the product performance.

1.3 Conditions with Potential Product Failure

- When the product transmitter and receiver lens is covered by dirt, there will be a risk of failures. Please keep the lens clean.
- The product will have a risk of failure when immersed completely in water. Do not use it underwater.
- When detecting objects with high reflectivity, such as mirrors and smooth tiles, the product may have a high risk of failures.



2 Physical Interface

2.1 Description about the line sequence and connection

Wiring terminal model: MH1.25-7P.

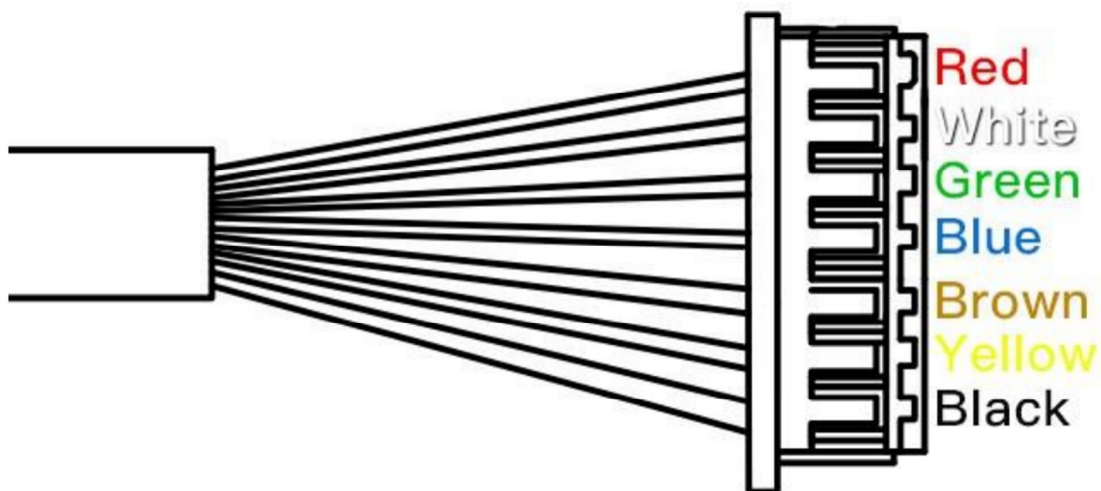

Figure 1: TF03 Line Sequence

Table 1 TF03 Pin functions and connection instructions

No	Color	Pin	Function
1	Red	VCC	Voltage Input
2	White	/	/
3	Green	/	/
4	Blue	I_out	4-20mA output current
5	Brown	TTL_RXD	UART Receiver
6	Yellow	TTL_TXD	UART Transmitter
7	Black	GND	Ground



2.2 Electrical Characteristics

This product has no overvoltage or polarity protection. Please ensure that the wiring and power supply are normal, and the supply voltage is allowed to fluctuate by $\pm 0.5V$.

Table 2 main electrical parameters

Parameter	Typical Value
Power supply voltage	12-24V
Average	$\leq 140mA @ 12V$ $\leq 80mA @ 24V$
Peak current	$\leq 140mA @ 12V$ $\leq 80mA @ 24V$
Average power	$\leq 2W$

3 Installation Instructions

3.1 Product Overview

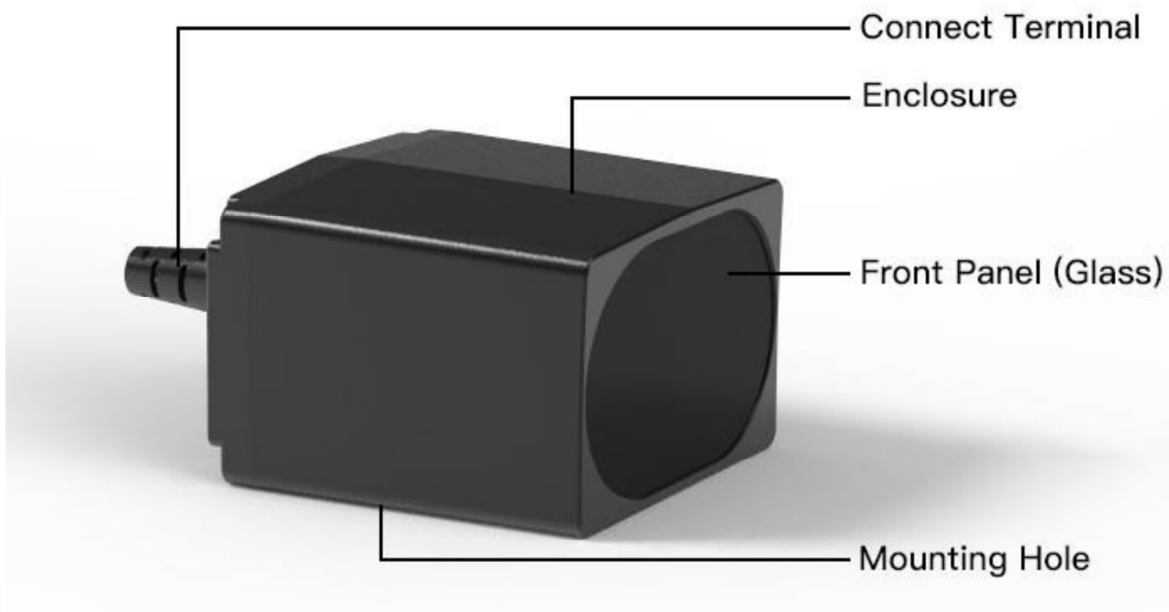

Figure 2: Exterior of TF03

3.2 Products Structure

The LiDAR mounting holes are applicable to M3 screws. Note that the length of the screw entering the enclosure shall be no more than 3.5mm.



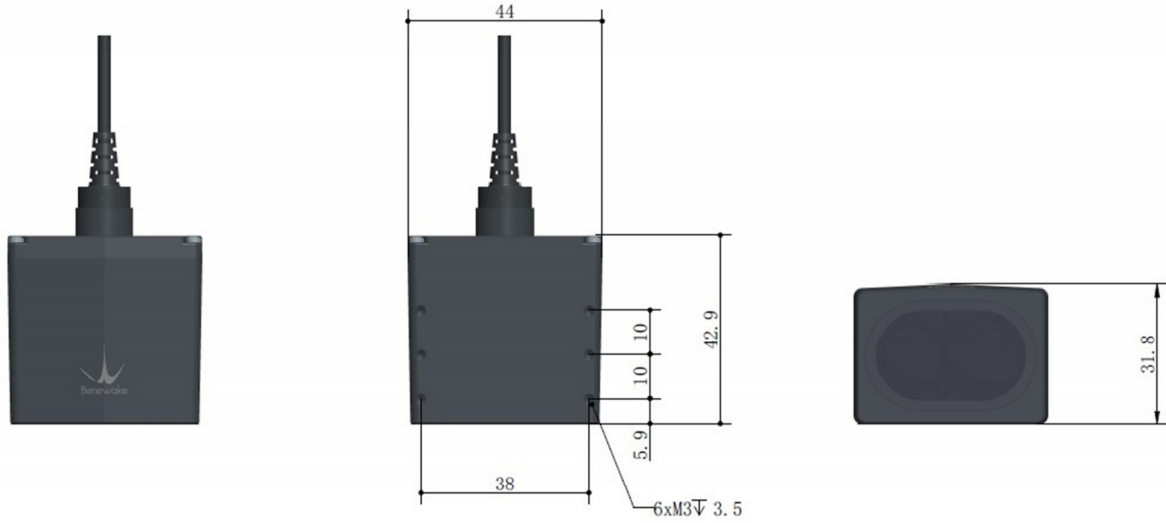

Figure 3: TF03 structure dimensions (Left 1: top view, Left 2: vertical view, Left 3: front view)

3.3 Detection Angle Descriptions

TF03 has a 0.5-degree detection angle and rectangular light spots; see Table 3 for simulated, diagrams of the light spots. Therefore, at different distances, the spot size, namely detecting range, is different as shown in Figure 4.

Note: The side length of common objects detected should be greater than that of the detection range of TF03; when the side length of the detected object is less than that of the detection range, the LiDAR effective range will be reduced

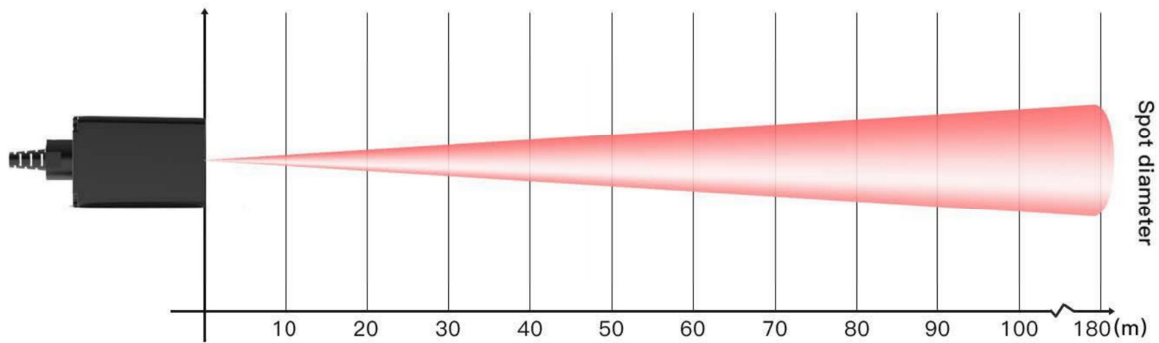
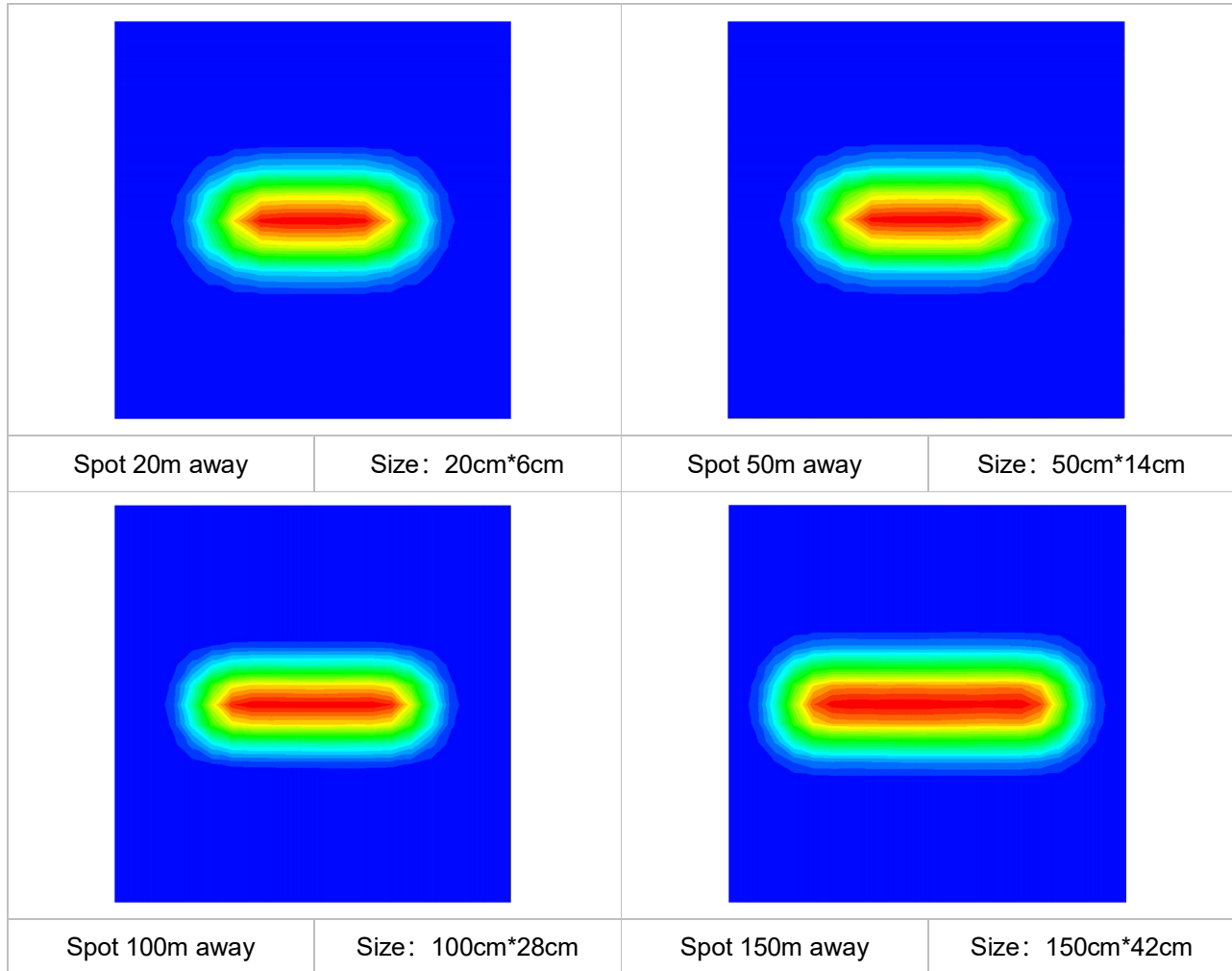

Figure 4: Detection angle schematic of TF03

Table 3: Spot simulated diagrams and sizes at different distances





Note: In the light intensity distribution of the spot, red is the strongest, green is weak, dark blue is the background, and the spot size is the length and width of the green in the figure.

4 Communication protocol and Data format

TF03 4-20mA version supports current analog output, TTL serial port is used for debugging purpose.

4.1 Communication Protocol

TF03 outputs 4-20mA analog quantity, the current size represents the distance size, divided into two modes, forward mode and reverse mode, the default is forward mode, see

Table 4 for details. The sampling resistance of the user is limited to less than 300 ohms. The distance value represented by 20mA current can be modified by the command to configure the over range value. For details, see 4.2.2.



Table 4 1.1 4-20mA analog version data description

Mode	Current Value	Distance Value	Description
Forward mode	4mA	0m	Default
	20mA	180m	
Reverse mode	4mA	180m	Can be modified by serial commands
	20mA	0m	

4.2 Custom parameter configuration

4.2.1 Instruction general format description

Custom parameters configurations are open in order that problems could be solved conveniently. Parameters, such as output data format, output frame rate could be changed by sending command. Parameter will be stored in flash and need not to be configured again if restart after configured successfully.

Please change the configuration according to the real demands and never try uncorrelated command frequently thus unnecessary loss from wrong command; please configure the product according to the demands of the manual and never send unstated command.

The Format of Command is:

Byte	byte0	byte1	byte2	byte3~ byteN-2	byteN-1
Descriptions	Head	Len	ID	Payload	Check sum

Head: fixed to 0x5A

Len: the length of the entire instruction frame (unit: Byte)

ID: identifies the function of each instruction

Payload: have different meanings and lengths in different ID instruction frames

Check sum: the lower 8 bits of the Len-1 byte data.



4.2.2 Commands

Function	Command	Response	Remark	Default Setting
Obtaining version number	5A 04 01 5F	5A 07 01 V1 V2 V3 SU	Version number V3.V2.V1 SU is check sum , the same below	/
System reset	5A 04 02 60	success: 5A 05 02 00 61 Failed: there isn't any reaction over 1s	/	/
Frame rate	5A 06 03 LL HH SU	Success: same as command Failed: there isn't any reaction over 1s	/	100fps
Reset to factory settings	5A 04 10 6E	Success: 5A 05 10 00 6F Failed: 5A 05 10 ER SU	Fail(when ER is not 0)	/
Save settings	5A 04 11 6F	Success: 5A 05 11 00 70 Failed: 5A 05 11 ER SU	Same as above	/
Configuring over range threshold value	5A 06 4F LL HH SU	Success: 5A 05 4F 00 AE Failed: there isn't any reaction over 1s	over range threshold value =(HH << 8) + LL, unit cm	18000
Enabling rain-fog algorithm	Enable: 5A 05 64 00 C3 Disable: 5A 05 64 01 C4	Success: 5A 05 64 00 C3 Failed: there isn't any reaction over 1s	/	Enable
Configuring offset	5A 06 69 LL HH SU	Success: 5A 05 69 00 C8 Failed: there isn't any reaction over 1s	Offset = (HH << 8) + LL, unit cm	0
4-20mA version configuration forward and reverse	Forward: 5a 05 71 00 d0 Reverse: 5a 05 71 01 d1	Success: 5a 05 71 00 D0 Failed: there isn't any reaction over 1s		Forward

Interpretation:

1) The supported output frame rate is as follows:

1、 2、 ...9、

10、 20、 ...90、

100、 200...900、

1000、 2000...9000、 10000;

2) When using the trigger mode, you need to disable data output, and then use the trigger command;



- 3) The Pixhawk data format is output as “x.yz\r\n”. For example, if the measurement distance is 1.21m, the string 1.21 will be output, followed by the escape character \r\n.

5 Quick Test Procedures

5.1 Test example

5.1.1 Test Range with Different Reflectivity

As shown in **Figure 5**, the 180m version of TF03, red and blue curves represent the relationship between the reflectance and range of the target under different ambient light intensities indoors and outdoors, respectively.

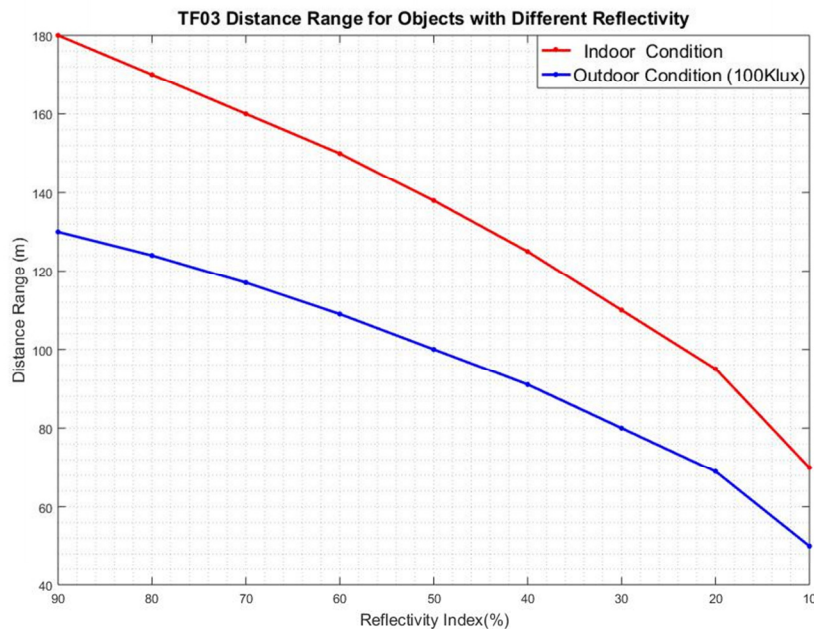

Figure 5 TF03 the relationship between TF03 range and reflectance (version 180m)

5.1.2 Testing Accuracy of Different Materials

The test accuracy of TF03 at different distances and reflectivity is shown in Figure 9. Two typical background boards (blackboard and whiteboard), are selected. The reflectivity of whiteboard is 90% and that of blackboard is 10%.



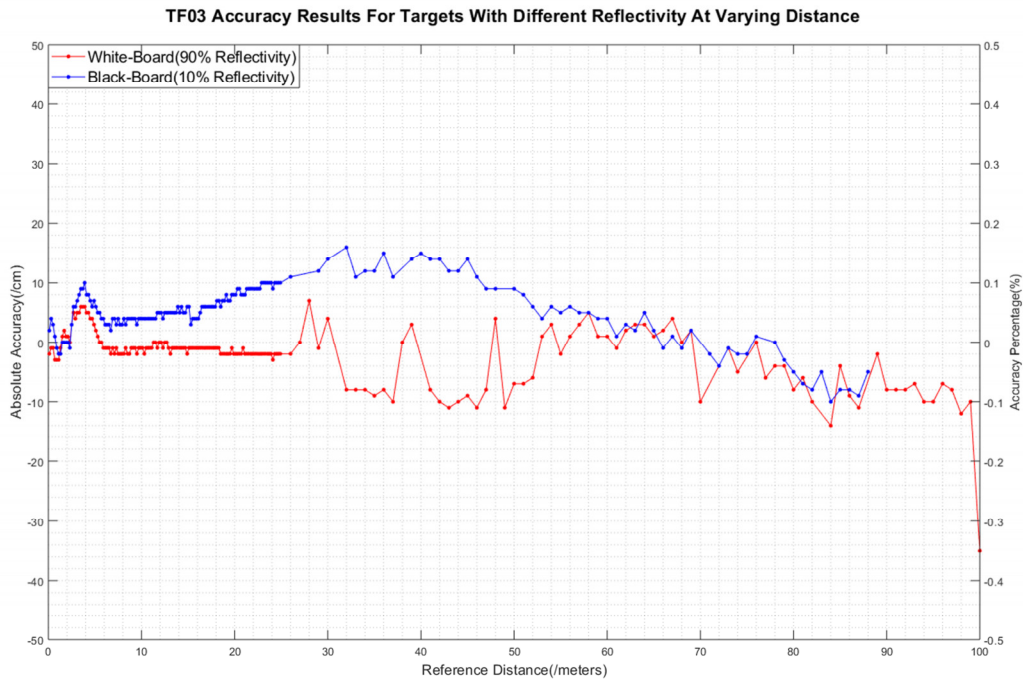

Figure 6: TF03 Error curves of TF03 at different distances and reflectivity

5.1.3 Reflectivity of Common Materials

The reflectivity of common materials is listed below, ranging from low to high. According to the test target and the corresponding reflectivity, we can measure whether the range of TF03 and other parameters meet the requirements.

S. No.	Material	Reflectivity
1	Black foam rubber	2.4%
2	Black cloth	3%
3	Black rubber	4%
4	Coal (varies from coal to coal)	4~8%
5	Black car paint	5%
6	Black paper	10%
7	opaque black plastic	14%



8	Clean rough board	20%
9	News papers	55%
10	translucent plastic bottles	62%
11	packing case cardboard	68%
12	Clean pine	70%
13	opaque white plastic	87%
14	white card	90%
15	Kodak standard whiteboard	100%
16	Unpolished white metal surface	130%
17	Shiny light metal surface	150%
18	stainless steel	200%
19	Reflective board, reflective adhesive tape	>300%

6 Frequently asked questions

Q1: Can TF03 support other voltage input.

A1: At present, other voltage input are not supported. If you have other needs, you can contact our sales staff for further inquiries about customization.

Q2: Can TF03 changes the data output frequency. Can the output be switched?

A2 : TF03 has currently opened custom parameter configuration and output mode adjustment. The switch function needs to be customized according to the needs. You can consult our sales or technical support for details.

Q3: : Can TF03 work normally in rain, snow and fog?

A3: TF03 has a firmware version of the algorithm that penetrates the rain and fog. Contact the sales or technical support personnel for firmware upgrade. The algorithm is turned on by default in V1.11.15.



Contact details

Headquarters:



010-57456983

Technical Support:



bw@benewake.com



support@benewake.com

