

L	15	
F	7	
a	7	

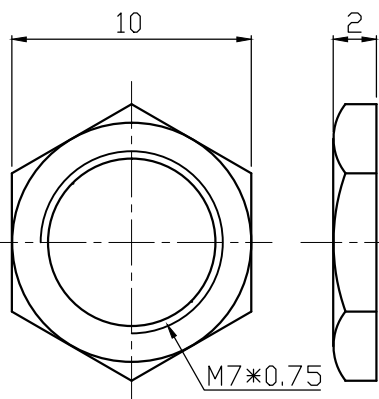

NUT 1pcs

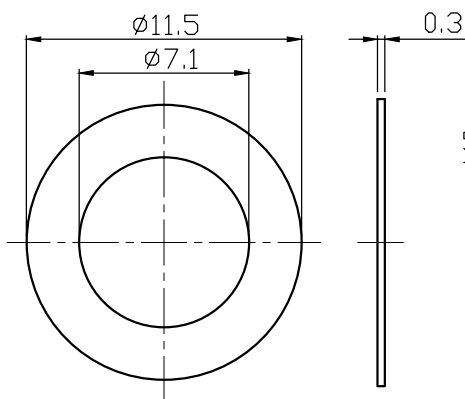

WASHR 1pcs

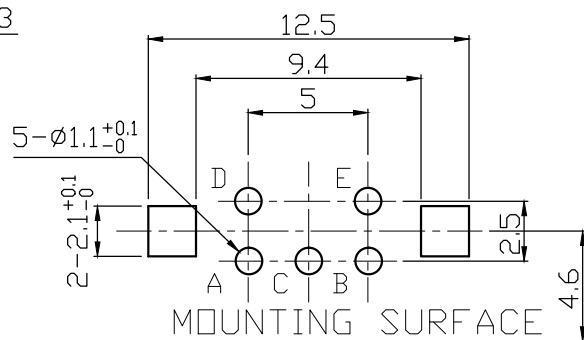

P. C. B. MOUNTING DETAIL

注：A-G为重点管控尺寸

宏彦科技（东莞）有限公司

HongYan Technology (Dongguan) Co., Ltd.

品名

EC11J 5DM15P1ZY15F7

图号

EC11J-008

日期

修改记录

绘制人

未标注尺寸公差

比例

3:1

2021/11/16

初始发行受控

谢地洋

L ≤ 10

±0.3

单位

mm

核准

审核

制图

10 < L ≤ 100

±0.5

版本

A0

100 ≤ L

±0.8

ANGLE

±5°

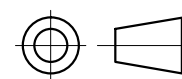

1. 一般事项General

1-1. 适用规格 Scope

本规格书适用于微小电流回路的电子设备，属11型回转型编码器。

This specification applies to 11mm size low-profile rotary encoder (incremental type) for microscopic current circuits, used in electronic equipment.

1-2. 标准状态Standard atmospheric conditions

除另有规定外，测量应在以下状态下进行：

Unless otherwise specified, the standard range of atmospheric conditions for making measurements and test is as following limits:

温度 Ambient temperature : 15°C to 35°C

相对湿度 Relative humidity : 25% to 85%

气压 Air pressure : 86kpa to 106kpa

如果对在上述所提到的条件中所做的实测值有疑问的话，应使用以下条件进行测量：

If doubt arises on the decision based on the measured values under the above-mentioned conditions, the following conditions shall be employed:

温度 Ambient temperature : 20±1°C

相对湿度 Relative humidity : 63% to 67%

气压 Air pressure : 86kpa to 106kpa

1-3. 使用温度范围

Operating temperature range : -30°C to +80°C

1-4. 保存温度范围

Storage temperature range : -40°C to +85°C

2. 构造Construction

2-1. 尺寸 Dimensions

见所附成品图 Refer to attached drawing

3. 额定值 Rating

3-1. 额定电压

Rated voltage: DC 5V

3-2. 最大额定电流（阻抗负载）

Maximum operating current (resistive load)

各相导线 Each lead: 0.5mA (Max 5mA; Min 0.5mA)

公共导线 Common lead: 1mA (Max 10mA; Min 0.5mA)

4. 使用上的事项Application Notes

4-1. 避免储藏于高温潮湿及腐蚀的场所。产品购入后尽可能在6个月内使用完。拆包装后未使用完的剩余产品需储藏于防潮防毒的环境下。

Avoid storing the products in a place at high temperature, high humidity and in Corrosive gases. Please use this product as soon as possible with 6 months limitation. If any remainder left after packing is opened, please store it with proper moistureproofing, gasproofing etc.

4-2. 编码器信号的计算方法应将操作的速度，信号的取样时间及电子回路中的微电脑软件等考虑进去。

The encoder pulses count method should be designed with taking operating speed, sampling time and design of the microcomputer software into consideration.

4-3. 此产品在定位点的输出波形参照（5-1），因此在设计软件时请留意其状态，推荐以A相位为参考基准。

With this products the detent position output consult fig. 5-1. Therefore make the A phase the reference at the software design stage. Recommended that use A output signal for the reference.

4-4. 在设计时要考虑到杂讯，建议使用R/C滤波电路，（图1）

At design of the pulse count process. Using the C/R filter circuit is Recommended. (fig .1)

4-5. 本产品请勿碰触到水，可能会导致输出波形的异常。

Care must be taken not to expose this product to water or dew to prevent possible problem in pluses output waveform.

图1 fig.1

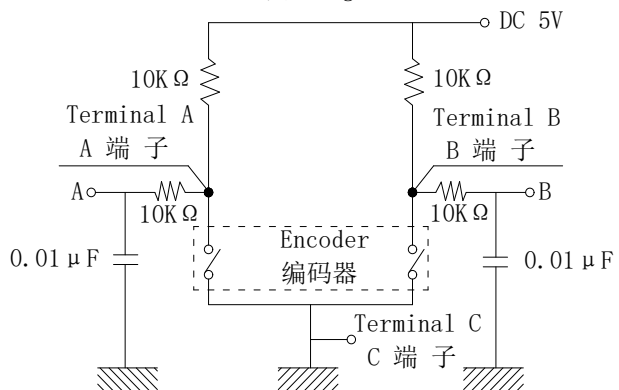

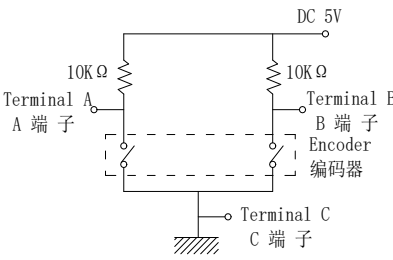
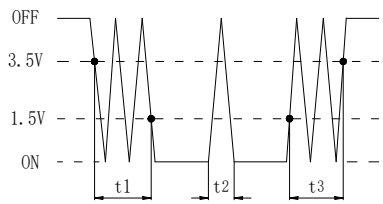
5. 电气性能 Electrical Characteristics			
项目 ITEM	条件 CONDITIONS	规格 SPECIFICATIONS	
5-1. 输出信号 Output signal format	A、B两信号输出相位差，输出波形详见图（图2/3）（虚线表示带卡点装置的上擎子处位置） 2 Phase-different signals (signal A, signal B) Details shown in fig.2/3 (The broken line shows detent position.)		
	轴回转方向 Shaft rotational direction	信号 Signal	
	顺时针方向 C. W	A(A-C端子间) A(Terminal A-C)	输出波形 Output
		B(B-C端子间) B(Terminal B-C)	图2 fig.2
逆时针方向 C. C. W	A(A-C端子间) A(Terminal A-C)	图3 fig.3	
	B(B-C端子间) B(Terminal B-C)		
5-2. 分解能力 Resolution	回转360° 的输出脉冲数。 Number of pulses in 360° rotation.	■ 15 个脉冲/360° (图2) 15 pulses/360° (fig. 2) □ 20 个脉冲/360° (图3) 20 pulses/360° (fig. 3)	
5-3. 开关特性 Switching characteristics	下（图4）所示回路，轴以360° /S的速度转动测定。 Measurement shall be made under the condition as follows. Shaft rotational speed : 360° /S Test circuit : (fig. 4) 图4 (fig. 4)  图5 (fig. 5) 		
5-3-1. 振荡 Chattering	编码从OFF→ON或ON→OFF时，输出1.5V~3.5V的通过时间。应符合规定Specified by the signal's passage time from 1.5V to 3.5V of each switching position(code OFF~ON or ON~OFF)	$t_1, t_3 \leq 3\text{mS}$	
5-3-2. 滑动杂讯 (突跳) Sliding noise (Bounce)	编码ON部份的1.5V以上的电压变动时间在振荡 t_1, t_3 之间会产生1mS以上, 1.5V以下的ON部份。另外, 如果各突跳1.5V以下的范围在1mS以上时, 则判定为另一个突跳。 Specified by the time of voltage change exceed 1.5V in code-ON area . When the bounce has code-ON time less than 1mS between chattering (t_1 or t_3) the voltage change shall be regarded as a part of chattering. When the code-ON time between 2 bounces is less than 1mS, they are regarded as 1 linked bounce.	$t_2 \leq 2\text{mS}$	

5-3-3. 滑动噪音 Sliding noise	编码OFF部份的电压变动。 The voltage change in code-OFF area.	3.5V以上 3.5Vmin
5-4. 相位差 Phase difference	下（图6）所示回路，轴以360°/S的速度转动测定。 Measurement shall be made under the condition which the shaft is rotated at 60r/min <p style="text-align: center;">图6 fig.6</p>	T1、T2、T3、T4≥0.08T 见图6 (fig.6)
5-5. 绝缘阻抗 Insulation resistance	在端子和支架间施加电压 250V DC。 Measurement shall be made under the condition which a voltage of 250V DC is applied between individual terminals and frame.	100MΩ 以上 100MΩ Min
5-6. 耐电压 Dielectric strength	在端子和支架间施加AC300V电压1分钟 A voltage of 300V AC shall be applied for 1 minute between individual terminals and frame.	不得有绝缘破坏 Without arcing or breakdown.
5-7. 端子间接触阻抗 Contact resistance	输出信号处于ON时安定状态条件下测定。 Measurement shall be stable condition which a output signal is ON.	1Ω 以下 1Ω Max
6. 机械性能 Mechanical Characteristics		
6-1. 全回转角度 Total rotational angle		360°（无止档点） 360°（Endless）
6-2. 定位点力矩 Detent torque	只适用于附卡点装置 Only suitable for C. C, equipment.	2~15mN. m. (20~150gf. cm)
6-3. 定位点数及位置 Number and position of detent	只适用于附卡点装置 Only suitable for C. C, equipment.	■30点定位间隔角度12° ±2° 30detents Step angle:12° ±2°
		□20点定位间隔角度18° ±2° 20detents Step angle:18° ±2°
6-4. 轴的推拉强度 Push-pull strength of shaft	在轴端，沿轴向施加 8Kg 的静负荷力推和拉各10秒钟（产品焊锡固定在PCB上。） Push and pull static load of 8Kg shall be applied to the shaft in the axial direction for 10s. (After soldering of the PC board)	轴向虚位间隙0.4以内 Shaft play in axial direction 0.4 Max
6-5. 端子强度 Terminal strength	在端子的先端施加5N（500g）的力1分钟。 A static load of 5N(500g)be applied to the tip of terminals for 1 minute in any direction.	端子无损坏，无过度的松动. 允许变形。 Without damage or excessive looseness of terminals. terminal bend is permitted.
6-6. 轴套螺纹紧固强度 Bushing Nut Tighten Strength		7.0kgf. cm以上 7.0kgf. cm Min
6-7. 轴向间隙 Shaft play in axial direction		0.4mm 以下 0.4mm Max
6-8. 轴摆动 Shaft wobble	在距离轴顶端5MM处，沿径向瞬间施加50mN. m(500gf. cm)的力测试 A momentary load of 500gf. cm should be applied at the point 5mm from the tip of the shaft in a direction perpendicular to the axis of shaft.	0.7*L/30mm p-p 以下（L：指安装平面到轴的柄端的距离。） 0.7*L/30mm p-p Max L:Distance between mounting surface and measuring point on the shaft
6-9. 轴的回转方向摆动 Shaft play in rotational wobble	用角度板测定。 Testing by angle board.	5° 以下 5° Max

7. 耐久性能 Endurance Characteristics		
项目 ITEM	条件 CONDITIONS	规格 SPECIFICATIONS
7-1. 回转寿命 Rotational life	在无负荷条件下轴以600~1000周/小时速度回转，一日连续5000~8000次。 The shaft of encoder shall be rotated at a speed of 600~1000cycles/H without electrical load, after with measurements shall be made. (5000 to 8000 continuous cycles for 24 hours.)	<p>■在力矩≤100gf.cm时30,000±200周 30,000±200cycles per below 100gf.cm.</p> <p>□在力矩>100gf.cm时15,000±200周。 15,000±200cycles per above 100gf.cm.</p> <p>振荡 t1, t3≤5mS. 突跳 t2≤3mS. 尚余有轻微定位感。 端子间接触阻抗200Ω以下 Chattering t1, t3≤5mS. Bounce t2≤3mS. Detent feeling has to remains Contact resistance 200Ω Max</p>
7-2. 耐湿性 Damp heat	温度40±2℃, 湿度90~95%的恒温恒湿槽中放置96±4小时后, 在常温、常湿中放置1.5小时后测试。 The encoder shall be stored at temperature of 40 ±2℃ with relative humidity of 90% to 95% for 96±4H in a thermostatic chamber. And the encoder shall be subjected to standard atmospheric conditions for 1.5H, After which measurements shall be made.	所有项应满足初期规格 Specifications in clause all items is shall be satisfied.
7-3. 耐热性 Dry heat	温度85±3℃的恒温箱中放置96±4小时, 常温、常湿放置1.5小时后测试。 The encoder shall be stored at a temperature of 85±3℃ for 96±4H in a thermostatic chamber. And then the encoder shall be subjected to standard atmospheric conditions for 1.5H, After which measurements shall be made.	所有项应满足初期规格。 Specifications in clause all items is shall be satisfied.
7-4. 低温特性 Cold	温度-40±3℃的恒温箱中放置96±4小时, 常温、常湿放置1.5小时后测试。 The encoder shall be stored at a temperature of -40±3℃ for 96±4H in a thermostatic chamber. And then the encoder shall be subjected to standard atmospheric conditions for 1.5H, After which measurements shall be made.	所有项应满足初期规格。 Specifications in clause all items is shall be satisfied.
7-5. 焊锡耐热性 Resistance to Soldering heat	槽焊 Dip soldering. 使用基板: t=1.6mm的单面覆铜板。 Printed wiring board: single-sided copper clad laminate board with thickness of 1.6mm. 预热: 基板表面温度100℃以下, 时间1分钟以内。 Preheating: 1. Surface temperature of board: 100℃. or less 2. Preheating time: within 1 minute. 焊接: 温度230±5℃或以下, 时间3秒以内。 Soldering: Solder temperature: 230±5℃ or less Immersion time: within 3S 手焊 Manual soldering. 温度300℃以下, 时间3秒以内。 Bit temperature of soldering iron: 300℃ less than Application time of soldering iron: within 3S	不得有绝缘体的破损、变形、接触无异常。 Electrical characteristics shall be satisfied No mechanical abnormality.
7-6. 焊锡性 Solderability	端子在230℃±5℃温度的焊锡槽内浸锡3秒±0.5秒。 The terminals shall be immersed into solder bath at 230℃ for 3S±0.5S.	浸渍面须有75%以上焊锡附着 A new uniform coating of solder shall cover 75% minimum of the surface being immersed.

推动开关部分 Push Switch Portion						□无 (N O)		■有 (Y E S)		
备注：以下规格适用于EC11编码器带开关系列。 Note: The following specification is only suitable for the one type with switch construction of RE11 encoder series.										
1. 额定值 Rating										
1-1. 额定电压										
Rated voltage: DC 5V										
1-2. 最大额定电流 (阻抗负载)										
Maximum operating current (resistive load): 10mA Max										
2. 电气性能 Electrical Characteristics										
项目 ITEM		条件 CONDITIONS				规格 SPECIFICATIONS				
2-1. 接触电阻 Contact resistance		用DC 5V 1mA 电压测定。 Voltage test at DC 5V 1mA.				≤100mΩ 100mΩ or less				
2-2. 绝缘阻抗 Insulation resistance		在端子和安装板间施加电压 250V DC. Measurement shall be made under the condition which a voltage of 250V DC is applied between individual terminals and bushing and plank.				100MΩ 以上 100MΩ Min				
2-3. 振荡 Bouncing		以1秒钟1往返 (OFF-ON-OFF) 按压动作。 Shaft shall be push at 1 cycles/s (OFF-ON-OFF)				≤10mS 10mS or less				
2-4. 耐电压 Dielectric strength		在端子和安装板间施加AC300V电压1分钟 A voltage of 300V AC shall be applied for 1 minute between individual terminals and bushing and plank.				不得有绝缘破坏 Without arcing or breakdown.				
3. 机械性能 Mechanical Characteristics										
3-1. 开关电路 接点数 Switch circuit and number of pulse						单极单投 (按压ON) Single pole and single throw (push ON)				
3-2. 开关动作力 Operation force of switch		在轴端，沿轴向施加的按压力。 Push static load to the shaft in the axial direction				500±200gf				
3-3. 开关移动量 Travel of switch						<input checked="" type="checkbox"/> 0.5±0.3 mm <input type="checkbox"/> 1.5±0.5 mm				
4. 耐久性能 Endurance Characteristics										
4-1. 按压寿命 Push-life		在无负荷条件下沿轴向施以1Kg以下的力，以600次/小时的速度按压。 Push 1Kg to the shaft of encoder in the axial direction under non-load conditions, and with a speed of 600 times/hour.				<input checked="" type="checkbox"/> 30,000±200次. (0.5行程) 30,000±200cycles. (0.5 Travel) <input type="checkbox"/> 15,000±200次. (1.5行程) 15,000±200cycles. (1.5 Travel) 接触电阻: ≤200mΩ. 其它应满足初期规格。 Contact resistance: 200mΩ or less. Specification in clause shall be satisfied.				
受控编号 Document No		修订 Revision		日期 Date		经办 Designed		审核 Check		批准 Approved
		初始发行		2020-10-15						
文号 File No										
EC11带开关15P正向专用										
版本 VERSION:		A0								